

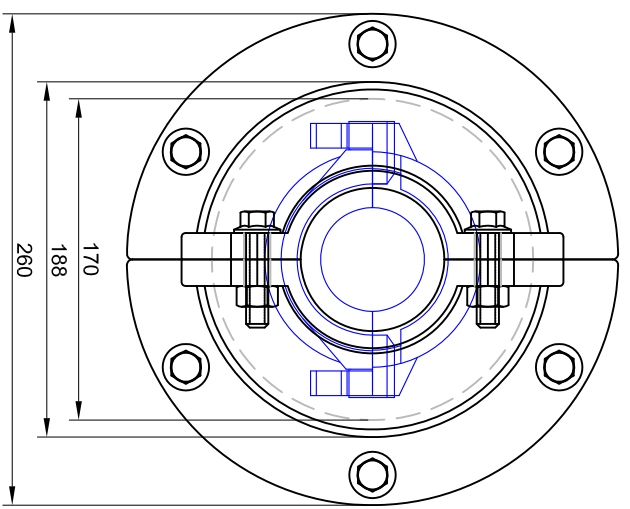

- Notes**
- Universal Coupling for joining any pipe with a shaft diameter of up to 73mm or with a maximum external socket diameter of 165mm.
 - Universal Coupling is used to join articulated pipe socket ends, or ball ends or repair broken pipes.
 - Material Spheroidal Graphite Cast Iron to ISO 1083/JS/400-15
 - Material Tensile strength 400MPa, Elongation 15%
 - Material wall thickness 9mm (+1 / -0.5mm)
 - General tolerances in accordance with ISO 8062-CT8
 - Requires bolting with fourteen A4 (316 grade) Stainless Steel M12 x 50mm bolts with washers and nuts
 - Weight of one Casting in air 9.5 kg (38 kg for a complete Universal Coupling of 4 castings)



| | | | |
|--|------------|--|----------|
|  | | <p>UTS Cable Limited 17-19 St. Georges Street, Norwich, NR3 1AB United Kingdom Tel: +44 1603 516242 Email: pipe@utscable.com www.utscable.com</p> | |
| Date: 01-09-20 | Scale: NTS | Sheet Size A3 | Issue: 3 |
| Code: 986-999-319-003 | | Application: Universal Coupling GA | |
| Title: Bulkhead Split Flange | | | |