

Example To Show 3 Extension Sleeve Pairs for Longest UJ Cable Joint

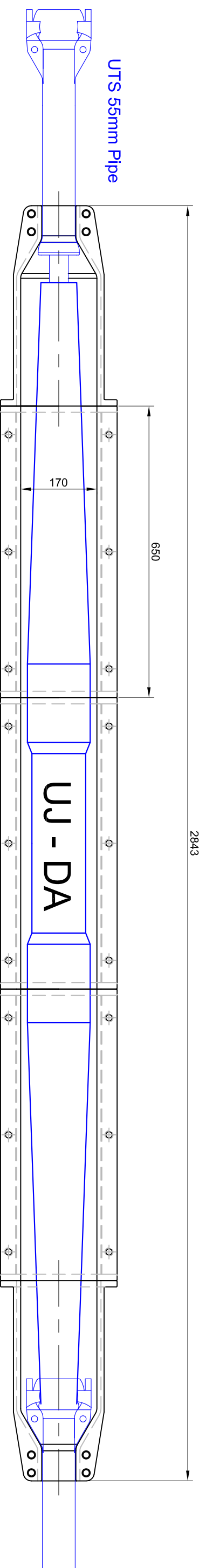

Example To Show 2 Extension Sleeve Pairs for UQJ or Short UJ Cable Joint

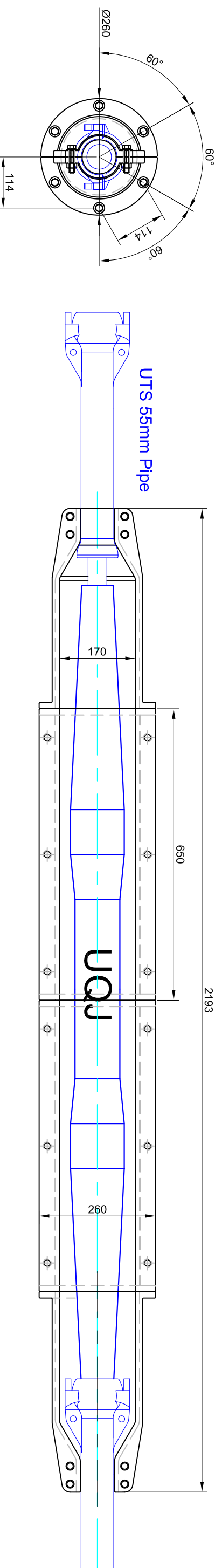

Notes

- Universal Coupling for joining any pipe with a shaft diameter of up to 73mm or with a maximum external socket diameter of 165mm.
- Universal Coupling used in conjunction with Extension Sleeve to provide cable joint protection and pipe continuity
- Material Spheroidal Graphite Cast Iron to ISO 1083/JS/400-15
- Material Tensile strength 400MPa, Elongation 15%
- Material wall thickness 9mm (+1 / -0.5mm)
- General tolerances in accordance with ISO 8062-CT8
- All dimensions in mm
- Requires bolting with A4 (316 grade) Stainless Steel M12 x 50mm bolts with washers and nuts
- Weight in air for one Extension Sleeve pair 34kg. Weight in seawater 29kg
- Weight in air for one Universal Coupling pair 19kg. Weight in seawater 16.2kg
- Weight in air for complete assembly with 2 extensions 106kg. Weight in seawater 90.5kg
- Weight in air for complete assembly with 3 extensions 140kg. Weight in seawater 119.6kg

Extension Sleeve

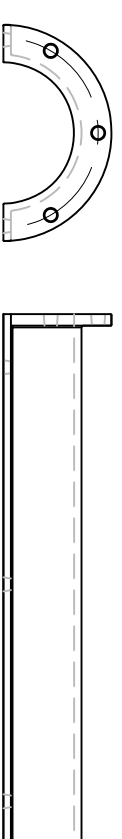

Universal Coupling

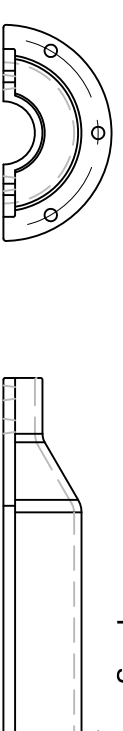

UTS Cable Limited

17-19 St. Georges Street, Norwich, NR3 1AB United Kingdom
 Tel: +44 1603 516242 Email: pipe@utscable.com www.utscable.com

Date: 01-09-2020

Scale: NTS

Dwg: 986-999-319-004

Issue: 3

Title: Pipe Protector for UJ or UQJ Cable Joints