

Technical Specifications

- Interlocking pipe halves with tool free assembly
- Internal diameter 55mm
- Effective installed length per segment pair 0.5m
- Material Spheroidal Graphite Cast Iron to ISO 1083/JS400-15/C
- Material Tensile strength 400MPa, Elongation 15%
- Material wall thickness 9mm (+1 / -0.5mm)
- Assembled minimum bending diameter >4m
- Weight per installed meter 17.6 kg in air, 15 kg in sea water
- General tolerances in accordance with ISO 8062-CT8
- Application and frequency of fixings to be determined by survey and customer specification. If fixings are chosen then recommend using two A4 (316 grade) Stainless Steel M12 x 50mm bolts with washers and nuts.

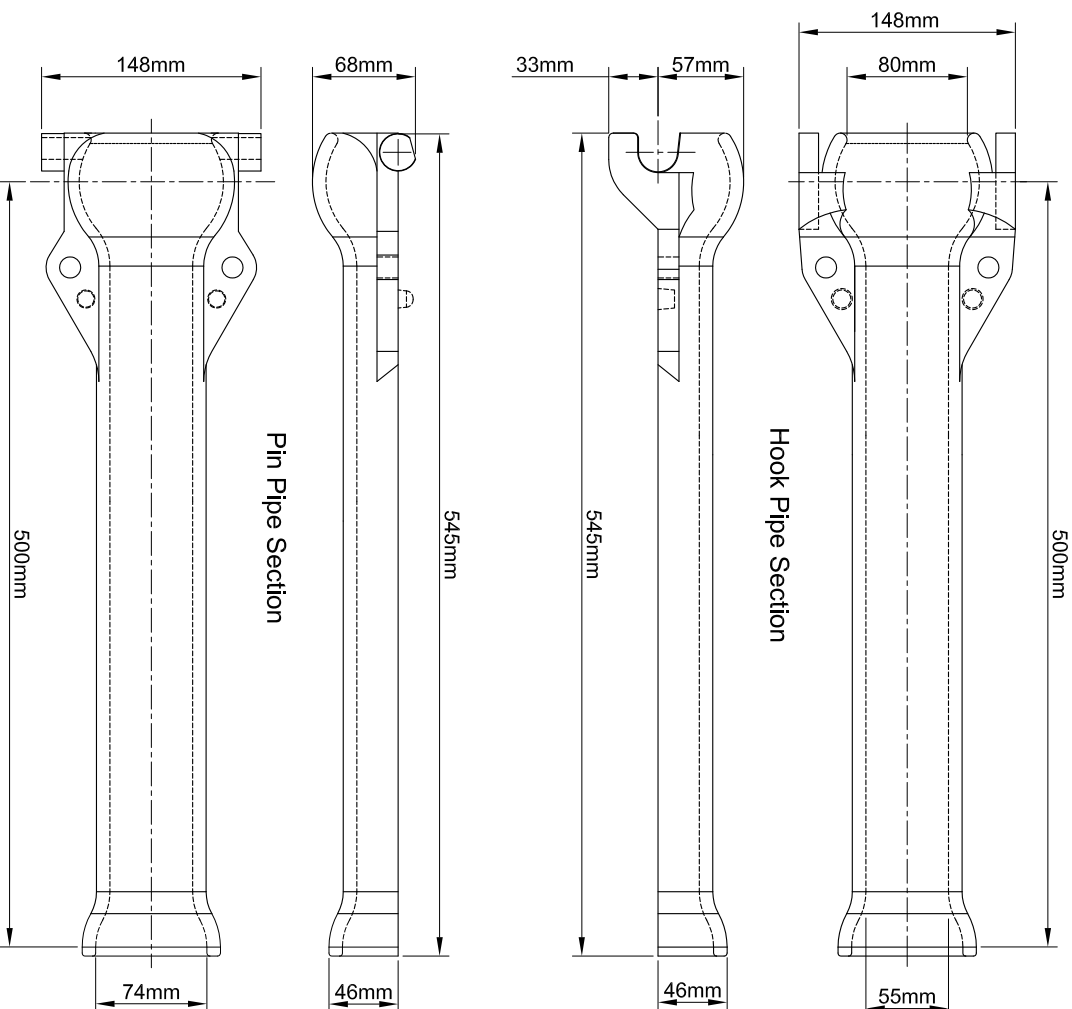

UTS Cable Limited

17-19 St. Georges Street, Norwich, NR3 1AB United Kingdom
 Tel: +44 1603 516242 Email: pipe@utscable.com www.utscable.com

Date: 01-09-2020 Scale: NTS Sheet Size A4

Code: 986-999-307-001 Issue: 4

Title: Articulated Split Pipe 55mm